

Technical Manual for RT-EX-9043D

Version 2.01



15 x Digital Output

Introduction

The EX9043D MODBUS I/O Expansion module is a high-quality and low-cost add-on data acquisition device that allows expanding the on-board digital output capabilities on X32-based RTCU units almost indefinitely and completely transparent using MODBUS communication protocol.

The EX9043D uses EIA RS-485 - the industry's most widely used bi-directional, balanced transmission line standard. It lets the module transmit and receive data at high data rates over long distances.

The EX9043D can be used to expand the RTCU with additional 15 digital outputs.

The EX9043D works in a variety of environments and applications, including:

1. Factory automation and control
2. SCADA applications
3. HVAC applications
4. Remote measuring, monitoring and control
5. Security and alarm systems, etc.

Table of Contents

Introduction	2
Table of Contents.....	3
Graphical view.....	3
Pin Assignment.....	3
Default Settings	5
LED Indicator	5
INIT* Pin Operation (Configuration mode).....	6
Wire Connections	7
Digital Outputs:	7
Technical Specifications	7
Appendix A – Using the module as I/O extension in the RTCU IDE.....	8

Graphical view



Pin Assignment

The 2 x 10-pins plug-terminals as seen in the following figure allow connecting supply, communication lines and digital outputs. The following table shows pin names and their function.

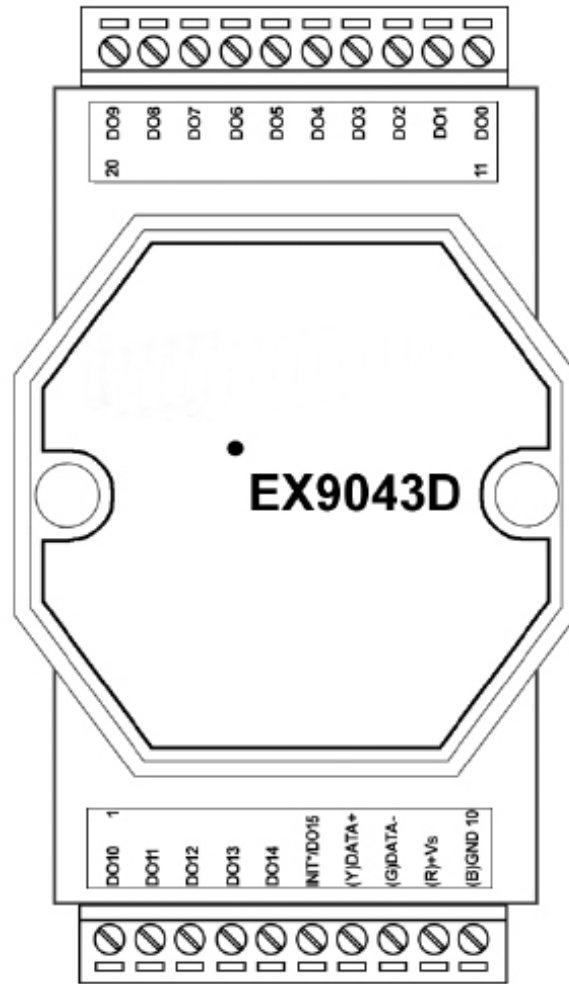

Pin	Name	Description
1	DO10	Digital output 10
2	DO11	Digital output 11
3	DO12	Digital output 12
4	DO13	Digital output 13
5	DO14	Digital output 14
6	INIT*	Pin for initialization of the configuration routine
7	(Y) DATA+	RS485+ data signal
8	(G) DATA-	RS485- data signal
9	(R) +VS	(+) Supply. Please refer to the specification for correct voltage level
10	(B) GND	Supply ground
11	DO0	Digital output 0
12	DO1	Digital output 1
13	DO2	Digital output 2
14	DO3	Digital output 3
15	DO4	Digital output 4

Pin	Name	Description
16	DO5	Digital output 5
17	DO6	Digital output 6
18	DO7	Digital output 7
19	DO8	Digital output 8
20	DO9	Digital output 9

Please refer to the section “Wire Connections” for correct wiring to the external device/sensor.

Default Settings

Name	Description
Baud rate	9600
Data bits	8
Parity	None
Stop bit	1
Device address	1

These settings can easily be changed in RTCU IDE. Please refer to “Appendix A – Using the module as I/O extension in the RTCU IDE” for details.

LED Indicator

The EX9043D is provided with a system LED to indicate power status, and LEDs to indicate state of their respective outputs. In the following table description of the different states of the LEDs can be found:

Name	Pattern	Description
System	ON	Power on
	OFF	Power off
Outputs	ON	Output is HIGH*
	OFF	Output is LOW*

**Please refer to the wiring scheme for correct indication*

INIT* Pin Operation (Configuration mode)

The module has a build-in EEPROM to store configuration information such as address, type, baud rate and other information. Sometimes a user may forget the configuration of the module, or simply need to change it. Therefore, the module has a special mode named "**INIT mode**" to allow the system to change the configuration. To enable INIT mode, please follow these steps:

6. Power off the module.
7. Connect the INIT* pin (pin 6) to the GND pin.
8. Power on the module.

The module is now ready to be configured, afterward remove the power.

When using the RTCU IDE to change the setting, select "setup module" from the right-click menu of the node in "I/O – Extension" tree, and a guide will go through each step of the configuration process. Please refer to the RTCU IDE on-line help for further information.

Wire Connections

Digital Outputs:

When connecting a device to the digital outputs please follow the wiring scheme below:

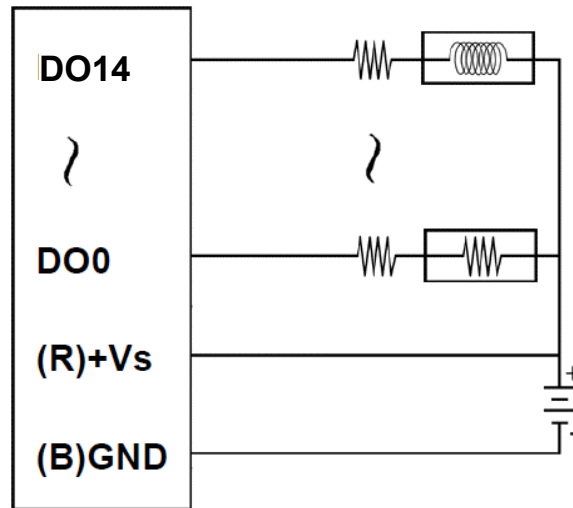

Please note that when connecting inductive load to the digital outputs a diode needed to prevent counter EMF.

Technical Specifications

Output Channels	15 open collector
• Isolation	None
• Load Voltage	Max to +30V
• Max Load Current	100 mA
Power Input	+10 V to + 30 V
Power Consumption	1,1 W
Operating Temperature	-25 ~ 75°C
Dual Watchdog Timer	√

Appendix A – Using the module as I/O extension in the RTCU IDE

To be able to use the MODBUS I/O Expansion module as an I/O extension, the RTCU IDE project needs to be configured correctly, by entering the correct parameters for the expansion module into the “I/O Extension device” dialog¹.

The following figure shows the correct setting for an EX9043 connected to the RS485_1 port on a RTCU DX4 with default settings:

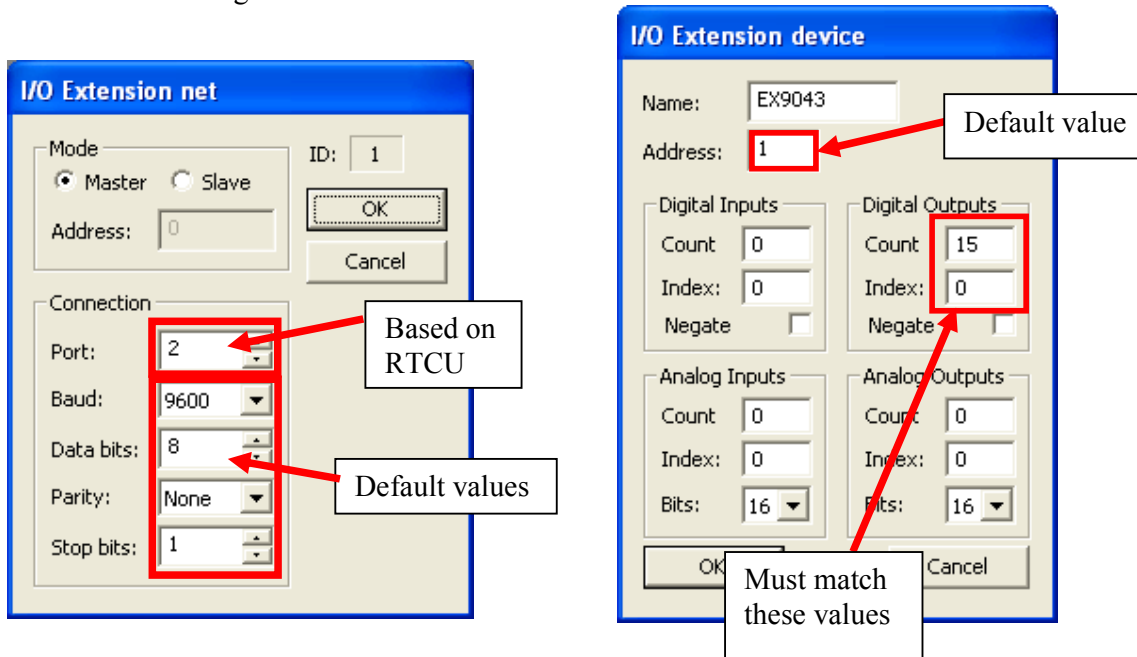

To change the above mentioned default values, new values must be entered and transferred to the module².

Values in the “I/O Extension net” must be set according to communication between the module and the RTCU unit, the port numeration follows the principles of the serOpen function, which is described in the IDE online help. When changing baud, data bit(s), parity or stop bit(s) all units on the net must be reconfigured³.

The address field is per default “1”; if more modules are connected to same net each must have a unique address. Changing the address of a module is done, by selecting the new value and then reconfigure the module.

A close attention must be paid to the Count, Index in the Digital Outputs section, which must be 15 and 0 respectively, else will communication with the module fail. Optional all writings can be inverted by selecting “Negate”.

¹ Please refer to the RTCU IDE online help for creating and editing I/O extension

² Please see “Project Control - I/O Extension” in the IDE online help.

³ To reconfigure: right click the device in the IDE and select “setup module”, and then follow the guide.