

RTCX LX9 eco

Advanced Industrial M2M/IoT Gateway



Technical Manual
Version 1.02

Introduction

The **RTCU LX9 eco** is a powerful successor to the **RTCU NX-910** with significant features, capacity, power, and security improvements. In addition, the **RTCU LX9 eco** is based on the latest **LX hardware architecture**, offering an unprecedented balance between price and performance.

The **RTCU LX9 eco** is positioned for a broad range of professional industrial Internet of Things applications.

The device rests on the **NX32L** (NX32 for Linux) architecture that embraces many new technologies and, at the same time, maintains full backward compatibility, which ensures that already implemented and tested **NX32** applications can execute without changes.

The **RTCU LX9 eco** device has been designed to meet the ever-increasing security challenges. It offers full TLS on all major protocols and includes a hardened protected execution environment with dual-boot and automatic fallback and recovery.

This manual contains technical documentation covering the installation and usage of the **RTCU LX9 eco** device. For detailed information on the product's programming and software configuration, please refer to the RTCU IDE documentation.

For detailed information on the powerful RTCU M2M Platform, please refer to the *RTCU M2M Platform datasheet*.

Table of Contents

Introduction	2
Table of Contents	3
Important Information	5
Difference between the RTCU LX9 eco and the RTCU NX-910.....	6
Technical Highlights.....	7
Graphical Overview	9
Connections.....	10
Overview	10
Power supply	13
DC Supply.....	14
AC Supply.....	15
Digital I/O.....	17
Relay outputs.....	17
Digital inputs / S0 inputs / Ignition input.....	18
Analog I/O.....	20
Analog inputs	20
USB programming port.....	22
RS232 communication ports (EIA/TIA-232 and V.28/V.24 compatible)	22
RS232 port 1	22
RS232 port 2	22
RS485 communication ports (EIA/TIA-485-A compatible).....	23
RS485 port 1	24
RS485 port 2	24
1-Wire	25
DC-Out 12/24VDC	25
LED Indicators.....	27
User LED A and B.....	27
Fault mode	27
System LED S1 and S2.....	28
Switches.....	30
DIP-Switch.....	30
System Switch (RST).....	30
Internal Li-Ion Backup Battery.....	31
Wireless Communication.....	32
LTE Cat. 1 Cellular Engine.....	32
Bluetooth LE.....	32
Internal SIM-Card reader.....	33
Micro SD-Card reader	34
Approved Micro SD cards.....	34
Antennas	36

Cellular Antenna.....	36
Bluetooth Antenna.....	36
Product Identification Label with Barcode	37
Power Consumption.....	38
Appendices	40
Appendix A – Device configuration guide	40
Appendix B – Installing the SIM card	43
Appendix C – Installing the Micro SD card.....	44
Appendix D - Open-Source Disclaimer.....	45
RTCU LX9 eco Specifications.....	46



Important Information



Thank you very much for using a product from Logic IO Aps. Our products are designed for professional use; therefore, this manual assumes technical knowledge and practice working with such products.

This documentation does not entail any guarantee on the part of Logic IO Aps with respect to technical processes described in the manual or any product characteristics set out in the manual. We do not accept any liability for any printing errors or other inaccuracies in the manual, unless it can be proven that we are aware of such errors or inaccuracies, or that we are unaware of these as a result of gross negligence and Logic IO Aps has failed to eliminate these errors or inaccuracies for this reason.

This product is a complex and sensitive electronic product. Please act carefully and ensure that only qualified personnel will handle and use the device. In the event of damage to the device caused by failure to observe the information in this manual and on the device, Logic IO Aps shall not be required to honor a warranty claim even during the warranty period and shall be exempted from the statutory accident liability obligation. Any attempts to repair or modify the product also voids all warranty claims.

Please contact Logic IO for any technical or commercial inquiries:

Logic IO Aps.
Holmboes Alle 14
8700 Horsens
Denmark
Phone: +45 76250210
Support: support@logicio.com
URL: www.logicio.com

Difference between the RTCU LX9 eco and the RTCU NX-910

The table below lists the main difference between the RTCU LX9 eco and the RTCU NX-910:

Feature	RTCU LX9 eco	RTCU NX-910																																								
Bluetooth LE	√	X																																								
Ethernet	X	√																																								
Angled terminals	<table border="1"> <thead> <tr> <th>FRONT</th> <th>BACK</th> </tr> </thead> <tbody> <tr> <td>SER1_TXD</td> <td>SER2_TXD</td> </tr> <tr> <td>SER1_RXD</td> <td>SER2_RXD</td> </tr> <tr> <td>SGND</td> <td>SER2_CTS</td> </tr> <tr> <td>SGND</td> <td>SER2_RTS</td> </tr> <tr> <td>1Wire</td> <td>SGND</td> </tr> <tr> <td>1Wire-LED</td> <td>N.M.</td> </tr> <tr> <td>485_SGND</td> <td>485_1_A</td> </tr> <tr> <td>485_2_A</td> <td>485_1_B</td> </tr> <tr> <td>485_2_B</td> <td>485_SGND</td> </tr> </tbody> </table>	FRONT	BACK	SER1_TXD	SER2_TXD	SER1_RXD	SER2_RXD	SGND	SER2_CTS	SGND	SER2_RTS	1Wire	SGND	1Wire-LED	N.M.	485_SGND	485_1_A	485_2_A	485_1_B	485_2_B	485_SGND	<table border="1"> <thead> <tr> <th>FRONT</th> <th>BACK</th> </tr> </thead> <tbody> <tr> <td>SER1_TXD</td> <td>SER2_TXD</td> </tr> <tr> <td>SER1_RXD</td> <td>SER2_RXD</td> </tr> <tr> <td></td> <td>SER2_CTS</td> </tr> <tr> <td>SGND</td> <td>SER2_RTS</td> </tr> <tr> <td>1Wire</td> <td>SGND</td> </tr> <tr> <td>1Wire-LED</td> <td>N.M.</td> </tr> <tr> <td>SGND</td> <td>RS485_1A</td> </tr> <tr> <td>RS485_2A</td> <td>RS485_1B</td> </tr> <tr> <td>RS485_2B</td> <td>SGND</td> </tr> </tbody> </table>	FRONT	BACK	SER1_TXD	SER2_TXD	SER1_RXD	SER2_RXD		SER2_CTS	SGND	SER2_RTS	1Wire	SGND	1Wire-LED	N.M.	SGND	RS485_1A	RS485_2A	RS485_1B	RS485_2B	SGND
FRONT	BACK																																									
SER1_TXD	SER2_TXD																																									
SER1_RXD	SER2_RXD																																									
SGND	SER2_CTS																																									
SGND	SER2_RTS																																									
1Wire	SGND																																									
1Wire-LED	N.M.																																									
485_SGND	485_1_A																																									
485_2_A	485_1_B																																									
485_2_B	485_SGND																																									
FRONT	BACK																																									
SER1_TXD	SER2_TXD																																									
SER1_RXD	SER2_RXD																																									
	SER2_CTS																																									
SGND	SER2_RTS																																									
1Wire	SGND																																									
1Wire-LED	N.M.																																									
SGND	RS485_1A																																									
RS485_2A	RS485_1B																																									
RS485_2B	SGND																																									

Technical Highlights

Platform:

- Based on the RTCU M2M Platform.
- **NX32L** (NX32 for Linux) execution architecture.
 - RTCU IDE development tool.
 - Operates under a full and highly optimized Linux variant.
 - Open and extendable with Platform SDK.

LX Hardware Core:

- Cortex-A7 32-bit ARM processor operating at up to 1 GHz.
- Cortex-M4 32-bit co-processor for advanced power management.
- Hardware floating-point and DSP instructions.
- 128 MByte RAM.
- 512 MByte NAND Flash (system boot, persistent memory, and filesystems).
- Real-time clock with a dedicated backup battery.

Security:

- Embedded firewall.
- TLS/SSL support with full certificate management.
- TLS/SSL support for all major TCP protocols, such as SMTP, MQTT, and sockets.
- Hardware-assisted encryption/authentication: AES-128, AES-192, AES-256, DES, TripleDES, HASH, RND and RSA signature.

Wireless Communication:

- LTE Cat. 1 Multi-Band Cellular Engine for EMEA.
- Internal SIM-card reader and support for eSIM.
- Bluetooth Low-Energy – BLE 5.3.

Wired Communication:

- 1-Wire bus for accessories such as ID-button reader, temperature sensors, etc.
- 2 x RS232 channels. One channel with RTS/CTS handshake.
- 2 x RS485 channels.

I/O Interfaces:

- 2 x analog inputs with 0..10 volt / 0..20 mA with 12 bit precision.
- 5 x digital inputs and 4 x high-power relays.
- 4 digital inputs can be configured as IEC62053-31 Class A compliant.
- Expandable I/O with standard Modbus modules.

Sensors:

- Temperature sensor.

User Interaction:

- 4 x bi-colour LED and 4 x position DIP-switch.
- High-speed Mini-USB service-port connector.

Audio:

- Fully digitized audio system.
- Digitized cellular audio.
- DTMF support for Interactive Voice Response applications.

Storage:

- Micro SD-CARD reader.
- Internal flash drive with up-to 64 Mbyte capacity.
- Persistent memory and circular datalogger.

Power and Battery:

- Wide AC/DC power operating range from 100..260VAC / 8..36 VDC.
- Onboard 1 Ah Li-Ion battery with intelligent charging.
- 12/24 Volt DC-out capability for powering external equipment.

Encapsulation:

- Housed in a ruggedized plastic encapsulation with cable glands.
- IP65 protected for outdoor usage.

Regulatory Approvals:

- Radio Equipment Directive, RED 2014/53/EU.
- EMC Directive, 2014/30/EU.
- 2011/65/EU RoHS Directive.

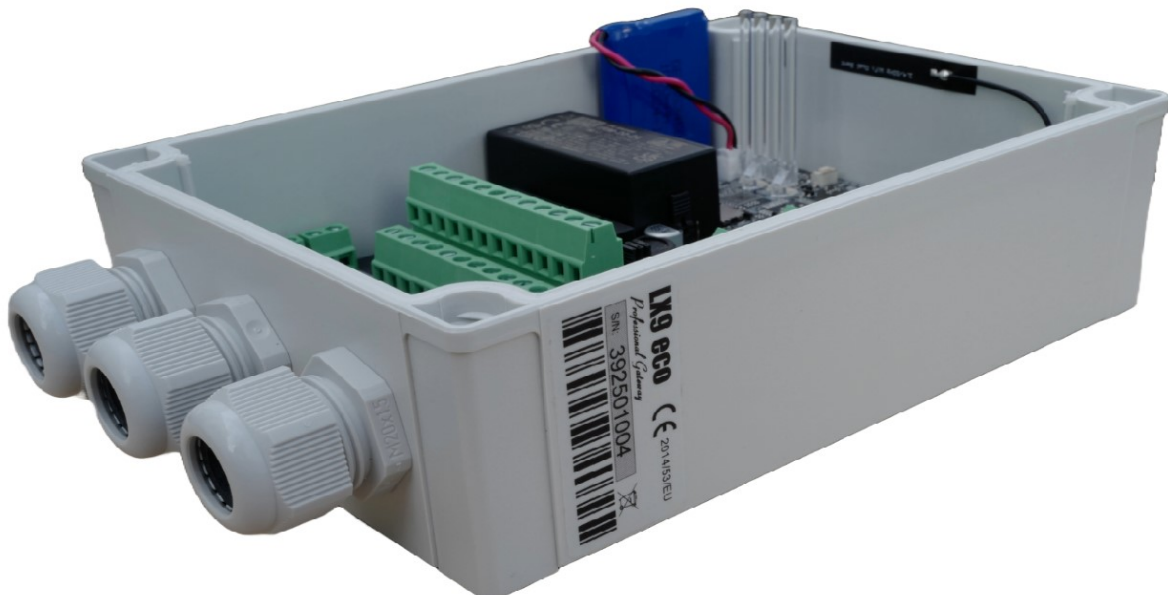

Graphical Overview

There are four user-controlled LEDs and four system LEDs for simple information and status on the front of the RTCU LX9 eco:

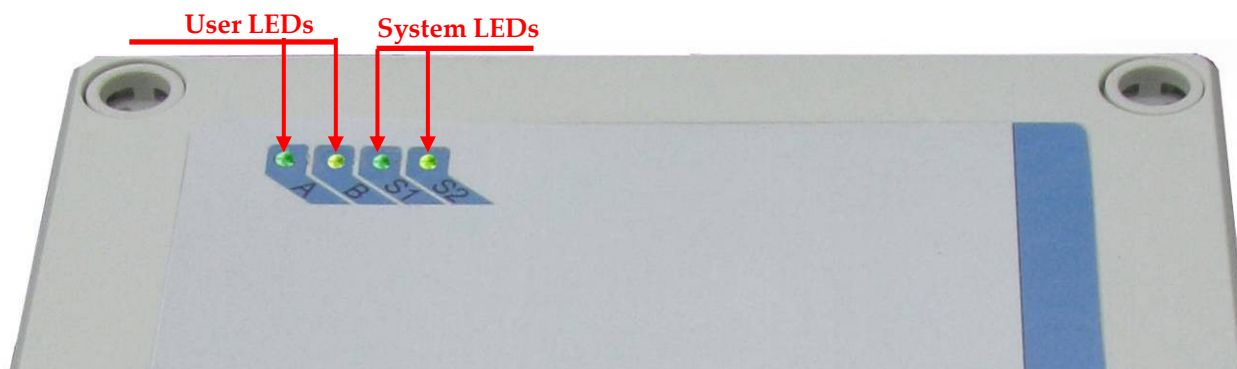

The external antenna connector is located at the top-side of the device, as shown below:

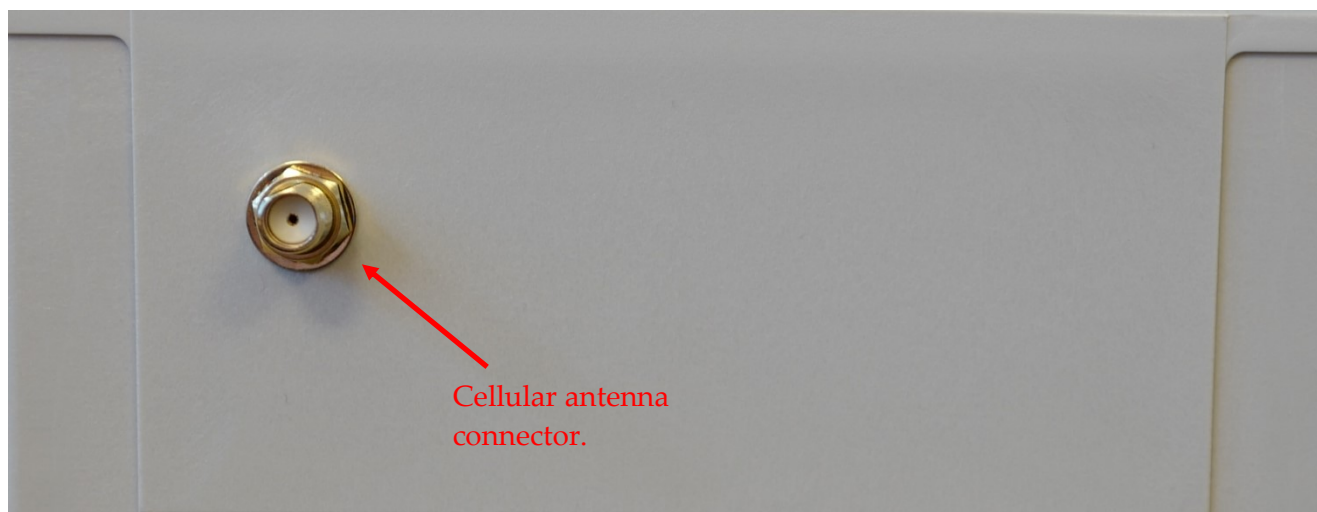

Connections

Overview

Connections to external equipment are done via large and easy-to-use screw terminal blocks which are accessible when the lid is removed. The placement of the terminals makes installation easy by using the cable glands, thereby maintaining IP-65 protection.

The RTCU LX9 eco is delivered with three M20 cable glands.

A graphical overview of the device is shown below:

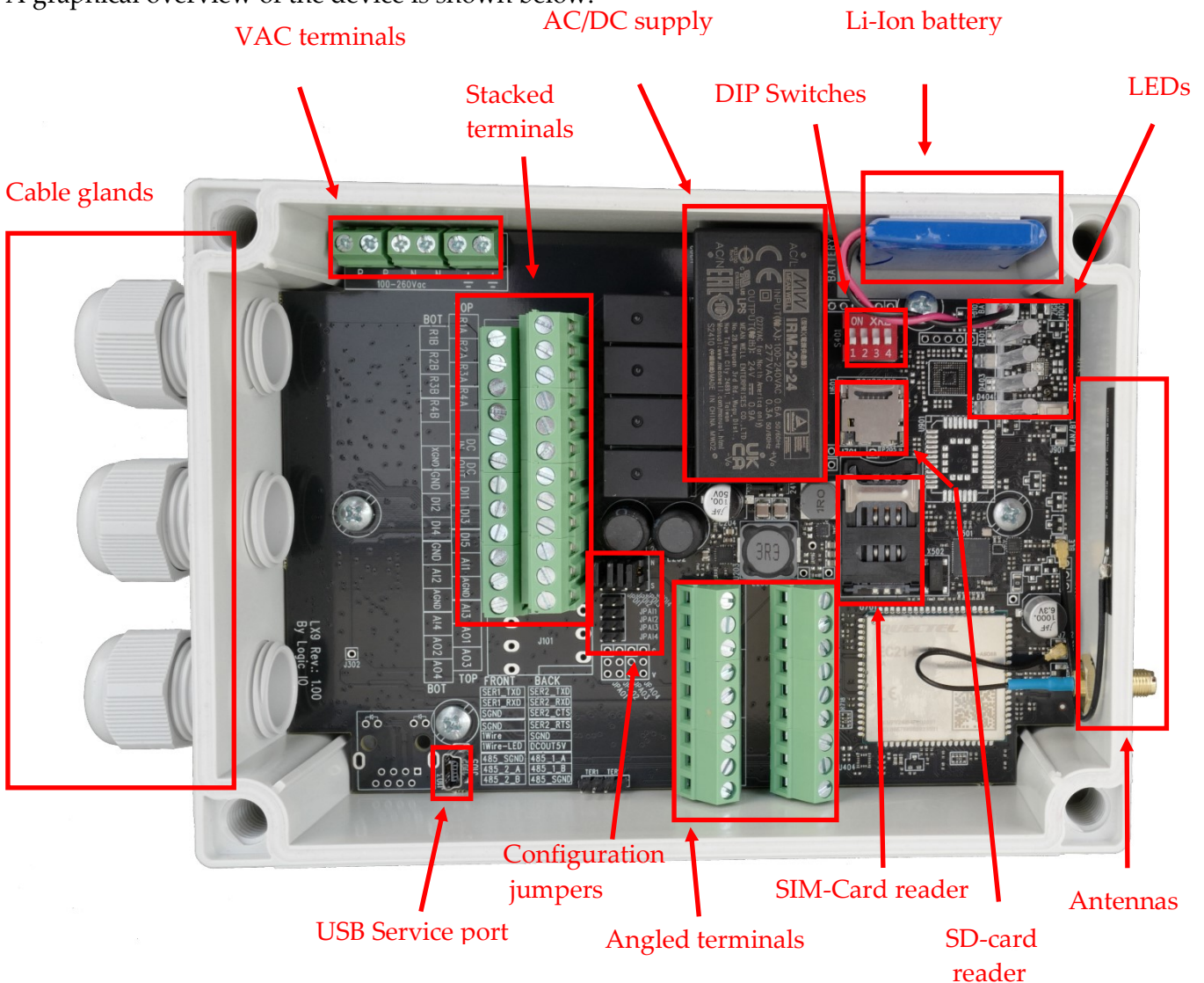

The stacked terminals contain connections for: Analog and digital inputs/outputs, 12V/24 DC-Output, and DC power input.

The angled terminals contain connections for the communication interfaces: RS232 Port 2, RS485 Port 1, RS485 Port 2, and 1-Wire.

Stacked terminal overview

Terminal Name		Description
TOP row	BOT row	
R1A		Contact set for relay output 1.
	R1B	
R2A		Contact set for relay output 2.
	R2B	
R3A		Contact set for relay output 3.
	R3B	
R4A		Contact set for relay output 4.
	R4B	
N.C		Not connected.
	N.C	Not connected.
DCIN		DC power supply, positive (+) connection.
	XGND	DC power ground, negative (-) connection.
DCOUT		12V / 500mA or 24V / 250mA DC output for external equipment.
	GND	Signal ground.
DI1		Digital input 1 / S0 input 1.
	DI2	Digital input 2 / S0 input 2.
DI3		Digital input 3 / S0 input 3.
	DI4	Digital input 4 / S0 input 4.
DI5		Digital input 5 / Wakeup (<i>ignition</i>) input.
	GND	Signal ground.
AI1		Analog input 1.
	AI2	Analog input 2.
AGND		Analog ground.
	AGND	Analog ground.



Angled terminal front row overview

Terminal Name	Description
SER1_TXD	Transmit data from serial port 1, RS232 compatible.
SER1_RXD	Receive data for serial port 1, RS232 compatible.
SGND	Signal ground.
SGND	Signal ground.
1Wire	1-Wire bus.
1Wire-LED	1-Wire ID-Button LED output.
485_SGND	RS485 Signal ground.
485_2_A	RS485 non-inverting signal for RS485 port 2.
485_2_B	RS485 inverting signal for RS485 port 2.

Angled terminal back row overview

Terminal Name	Description
SER2_TXD	Transmit data from serial port 2, RS232 compatible.
SER2_RXD	Receive data for serial port 2, RS232 compatible.
SER2_CTS	Clear-To-Send for serial port 2, RS232 compatible.
SER2_RTS	Request-To-Send for serial port 2, RS232 compatible.
SGND	Signal ground.
NC	Internally not connected
485_1_A	RS485 non-inverting signal for RS485 port 1.
485_1_B	RS485 inverting signal for RS485 port 1.
485_SGND	RS485 Signal ground.

VAC terminal overview

Terminal Name	Description
N	100-260VAC (50/60Hz) Neutral input.
N	<i>(internally tied together)</i>
P	100-260VAC (50/60Hz) Phase input.
P	<i>(internally tied together)</i>
	Protective earth terminal for the AC power.
	<i>(internally tied together)</i>

Connector Mini USB-B

The USB port is for programming and communication with the RTCU IDE (RACP-compliant application). A standard USB cable with an USB-B end can be used between the device and the PC

Power supply

The RTCU LX9 eco device can be supplied with either 100-260VAC (50/60Hz) or 8-36VDC or both supply types simultaneously.

The RTCU LX9 eco also contains an internal low-capacity backup battery, which will supply the RTCU if the external power fails or is disconnected. By default, the RTCU LX9 eco is powered down when a power fail occurs. This setting, however, can be changed. Please consult the RTCU-IDE on-line help for more information.

When the wakeup/ignition input is activated with a logical high, the RTCU LX9 eco device will wake up if it is in power-down mode.

There are six different ground labels:

- External DC Supply Ground (XGND)
- Signal Ground (SGND)
- Digital Ground (GND)
- Analog Ground (AGND)
- RS485 Ground (485_SGND)
- AC Supply Ground (Protective Earth, PE).

The signal ground (SGND), digital ground (SGND), and analog ground (AGND) are filtered from the power ground.

External DC supply ground (XGND) must only be used as a DC power supply return path.

The RS485 ground (485_SGND) is connected to the system ground through 1Mohm resistor in order to protect the system.

The AC supply ground is (PE) used in order to have a common reference between external AC powered system and the internal system.

The digital ground (GND) is used as ground reference for digital I/O's, signal ground is used as a ground reference for serial interfaces, and the analog ground is used as a low-noise analog ground reference for the analog inputs.

Dual Supply Note:

The RTCU LX9 eco can be supplied with both VAC and VDC simultaneously. The device will run on the VAC supply if the VDC supply voltage is < +24VDC. If the VDC supply voltage is higher, it will run on the VDC supply.

Please refer to the RTCU on-line help for information on how to check the supply type from within an application.

DC Supply

The RTCU LX9 eco can be supplied with 8-36VDC from an external DC power source. Positive power is applied to the DCIN pin, and ground is connected to the XGND pin.

The DC supply of the RTCU LX9 eco is protected against wrong polarity. If a system ground is connected to either SGND or AGND, a wrong polarity on the supply lines will destroy the internal GND connection.

Please Note:

- Minimum 15VDC supply is necessary for 0-10V analog output and 12V DC out.
- Minimum 16VDC supply is necessary for digital inputs 1-4 to work as S0-compliant inputs.

VDC Supply terminals

Terminal Name	Description
DCIN	Power supply, positive (+) connection.
XGND	Power ground, negative (-) connection.

AC Supply

The RTCU LX9 eco device can be supplied with 100-265VAC (50/60Hz) from a standard wall plug or any other high-voltage VAC power rail.

The AC supply of the RTCU LX9 eco is a highly efficient switch mode power supply, and the AC input is protected internally with a 2A/250V Fast Acting non-replaceable fuse.

AC power must be applied between the N and P on the designated screw terminals.

Protective Earth (PE) connection terminals are labeled with the sign .

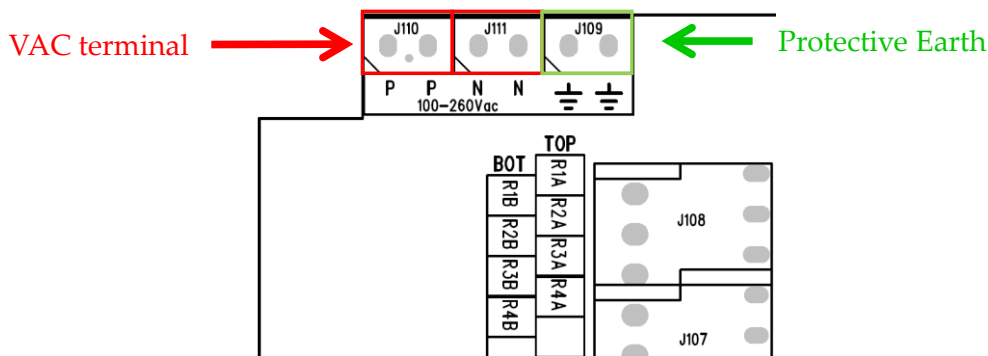

VAC Supply terminals

Terminal Name	Description
N	100-260 VAC (50/60Hz) Neutral input
N	(internally tied together)
P	100-260 VAC (50/60Hz) Phase input
P	(internally tied together)
	Protective Earth connector

Please Note:

The two pairs of N and P terminals and the terminal marked with  are internally connected.

There is high voltage in certain areas of the PCB (printed circuit board) when supplied with AC mains. There is a risk of electrical hazards; therefore, avoid touching the PCB and the components during operation.



Be aware that the supply filter contains capacitors that may remain charged after the equipment is disconnected from the supply. Although the stored energy is within the approved safety requirements, a slight shock may be felt if the plug pins are touched immediately after removal.

Refer all servicing and handling to qualified personnel.

Please note:

The DC ground of the RTCU LX9 eco is isolated from the AC ground because of the nature of AC-to-DC converting. As these two grounds are not tied together anywhere in the RTCU LX9 eco, the DC ground may appear as "floating ground" to the outside if the RTCU LX9 eco ground is not connected to the same reference as the outside, and a potential difference may occur. This difference can interrupt the device's behavior and in the worst case, damage that part of the device. This must be considered when the RTCU LX9 eco devices are supplied with AC supply. When the RTCU LX9 eco is supplied with DC voltage, this "potential difference" issue may not be observed as the DC power supply usually has the same potential as the rest of the system.

In order to avoid this, the **Earth** connection on the AC supply rail can be connected to the terminal that has been marked with the symbol .

For circuitry in situations where significant Earth ground currents can flow, isolating the DC ground from Earth grounds may be desired. In this case, the DC ground may be tied together with the Earth ground through a high impedance connection.

For the best EMI performance/ESD immunity in combination with a common reference it is recommended to connect DC ground and Earth together with a low-inductance connection.

Digital I/O

The RTCU LX9 eco has five digital inputs and four normally-open relay outputs. The outputs are high performance relays with good current handling capabilities.

Digital input 1-4 have multiple operating modes. Please refer to the digital input section for additional information.

Relay outputs

The digital outputs control four relays, and they act like normally-open contacts, where one side must be connected to a source that needs switching and the other contact terminal is the output. The source can be either VAC or VDC, but the maximum switchable voltage and current must not be exceeded. Please refer to the specification page.

There are no internal connections to the relay outputs, and a source must always be connected to one of the relay terminals for the output to work.

The RTCU LX9 eco device offers a very advanced power management, which makes it possible to have one or more outputs enabled while the RTCU is in low-power mode. Please consult the RTCU IDE on-line help for more information. The relays are fully operational when the device is operating from the internal battery.

Relay output terminals

Terminal Name	Description
R1A R1B	Contact set for relay output 1.
R2A R2B	Contact set for relay output 2.
R3A R3B	Contact set for relay output 3.
R4A R4B	Contact set for relay output 4.

Load noise

If highly inductive loads (such as high-power contactors) are connected to the relays, it may in certain cases be necessary to externally connect a clamping diode parallel with each inductive DC load or connect an RC snubber circuit parallel with each inductive AC load.

For DC applications, Vishay UF5405-E3/54 or similar is recommended, and for AC applications, AMPOHM FE-SP-HDR23-47/100 (47nF/100 ohm) or similar is recommended.

Digital inputs / S0 inputs / Ignition input

The five digital inputs are all low-pass filtered and transient-protected. A positive voltage is connected between the corresponding input (DINx) and GND to activate the inputs.

Digital inputs 1-4 can be configured individually as S0 inputs (IEC62053-31, Class A), and DIN5 can work as wakeup (ignition) input.

By default, the digital inputs are configured as normal inputs. Please refer to the configuration guide in Appendix A for the placement and configuration of the hardware jumpers inside the device.

S0 compliant inputs (IEC62053-31, Class A compatible)

In S0 configuration, the relevant RTCU LX9 eco input will act as a 'pulse input device', and a current is supplied into the input connector so that a simple switch between GND and the appropriate input will activate it. This is used in most electricity metering equipment.

Please note: The RTCU LX9 eco device must be supplied with a minimum of 16 VDC or AC power for the S0 mode to be compliant to the standard.

S0 is disabled by default and must be enabled by the application.

Wakeup (*ignition*) input

The DI5 / wakeup (*ignition*) input is a special input as it also functions as the ignition. If the input is activated with a logical high when the RTCU LX9 eco is in power down mode, it will wake the device. A power apply will also wake the device up if it is in power-down mode.

In the other power-saving modes, all the inputs and power apply/fail can be used to wake the device with individually configured falling- or rising edge detection. Please consult the RTCU IDE on-line help for more information.

For placement and configuration of the hardware jumpers inside the device, please refer to the device configuration guide in Appendix A.

Digital input terminals

Terminal Name	Description	Jumper Setting
DI1	Digital input 1 or S0 input 1	JPDI1 in position N (<i>default</i>) JPDI1 in position S
DI2	Digital input 2 or S0 input 2	JPDI2 in position N (<i>default</i>) JPDI2 in position S
DI3	Digital input 3 or S0 input 3	JPDI3 in position N (<i>default</i>) JPDI3 in position S
DI4	Digital input 4 or S0 input 4	JPDI4 in position N (<i>default</i>) JPDI4 in position S
DI5	Digital input 5 and Wakeup (<i>ignition</i>) input	
GND	Digital Ground	

Specification for each digital input

	Min.	Typ.	Max.	Unit	
Logic "High"	8	12	40	VDC	Protected against transients and low-pass filtered
Logic "Low"	-5	-	3	VDC	
Bandwidth (normal)	-	15	-	kHz	@ 12 VDC input voltage level
Bandwidth (s0)	-	3	-	kHz	
Input impedance	-	13.8	-	k Ω	In "normal digital input" mode

Analog I/O

Analog inputs

The RTCU LX9 eco device has two analog inputs, which can be configured individually as voltage or current measurement inputs using the configuration jumper. The range in voltage mode is 0-10VDC, and in current mode 0-20mA. The conversion resolution is 12 bits.

By default, the analog inputs are configured as voltage inputs and are converted to a digital value with a resolution of 10-bit before being presented to the application (0..1023). The application can change the resolution to the full 12-bit (0..4095). Please consult the RTCU IDE for further details.

The input signal is connected between AIx and AGND. AGND must be connected to the reference of the connected equipment. Please be aware that deviations may occur, as the system is very noise-sensitive. Avoid long, unshielded wires and high-current, fast-changing signals routed parallel to the analog signals.

The inputs are low-pass filtered, ESD- and transient-protected.

By default, the inputs are configured as voltage inputs. Please refer to the device configuration guide in Appendix A for the placement and configuration of the hardware jumpers inside the device.

Analog input terminals

Terminal Name	Description	Jumper Setting
AI1	Analog input 1 – Voltage	JPAI1 not installed (<i>default</i>)
	Analog input 1 – Current	JPAI1 installed
AI2	Analog input 2 – Voltage	JPAI2 not installed (<i>default</i>)
	Analog input 2 – Current	JPAI2 installed
AGND	Analog ground	
AGND	Analog ground	

Specification for each analog input (voltage mode)

	Min.	Typ.	Max.	Unit	
	0	-	10	VDC	Protected against transients and
Resolution	-	-	12	Bit	low-pass filtered
Accuracy	-	0.2	0.25	%FSR	Accuracy is based on measurements
Cut-off frequency	-	4.5	-	kHz	@ 25 °C
Input impedance	-	40	-	kΩ	

Specification for each analog input (current mode)

	Min.	Typ.	Max.	Unit	
	0	-	20	mA	Protected against transients and
Resolution	-	-	12	Bit	low-pass filtered
Accuracy	-	0.2	0.25	%FSR	Accuracy is based on measurements
Cut-off frequency	-	4.5	-	kHz	@ 25 °C
Input impedance	-	500	-	Ω	

USB programming port

The mini-USB port is for programming and communicating with the RTCU IDE (or other RACP compliant applications). A standard USB cable can be used between the device and the PC.

RS232 communication ports (EIA/TIA-232 and V.28/V.24 compatible)

Two general-purpose RS232 ports are available on the RTCU LX9 eco device. Both ports are compliant with the EIA/TIA-232 standard.

RS232 port 1

This port is a general-purpose RS232 serial port and does not support handshaking. The signals are available on the angled front row terminals.

SER1 terminals

Terminal Name	Description
SER1_TXD	Transmit data from serial port 1, RS232-compatible.
SER1_RXD	Receive data for serial port 1, RS232-compatible.
SGND	Signal ground.

This RS232 port must be addressed as **port 0** when using the VPL API, such as the serOpen function.

RS232 port 2

Serial port 2 is a general-purpose RS232 port with RTS/CTS handshaking signals present. The signals are available on the angled back row terminals.

SER2 terminals

Terminal Name	Description
SER2_TXD	Transmit data from serial port 2, RS232-compatible.
SER2_RXD	Receive data for serial port 2, RS232-compatible.
SER2_CTS	Clear-To-Send.
SER2_RTS	Request-To-Send.
SGND	Signal ground.

This RS232 port must be addressed as **port 1** when using the VPL API, such as the serOpen function.

RS485 communication ports (*EIA/TIA-485-A compatible*)

RS485 is a multi-drop network with a maximum of 32 devices connected simultaneously to the bus. The RS485 bus contains an RS485+ (*non-inverting*) and an RS485- (*inverting*) signal as well as a signal ground, which must always be connected to the common signal ground for all devices connected to the RS485 bus.

The maximum cable length for the RS485 bus is according to the EIA/TIA-485-A standard (max. 1200m @ <100kbit); the quality of the cable, signaling rate, noise etc, highly influences this limit.

At longer cable lengths, noisy environments, or high communication speeds, it might be necessary to terminate the transmission line with a 120¹ ohm resistor at each end of the transmission line to terminate it and avoid signal reflections.

When the RTCU LX9 eco device is used as an endpoint device, the hardware jumpers TER1 and TER2 can be installed to terminate the RS485 communication lines with 120Ω.

Both RS485 ports can be used as general-purpose RS485 serial port or as I/O extension module(s) port. When used with supported MODBUS IO extension modules, general-purpose use is disabled. The RS485 port signals are available on the angled terminals.

Further details on the MODBUS I/O extension modules and their use are available in the RTCU IDE on-line help.

By default, the RS485 communication lines are not terminated with 120 Ω. Please refer to the configuration guide in Appendix A for the placement and configuration of the hardware jumpers inside the device.

¹ Assuming use of a CAT5 twisted pair cable

RS485 port 1

RS485 signals are available on the angled back terminals.

If the TER1 jumper is inserted, a 120Ω endpoint resistor is enabled. For the location of TER1 refer to Appendix A

RS485 port 1 terminals

Terminal Name	Description
485_1_A	RS485 non-inverting signal (A)
485_1_B	RS485 inverting signal (B)
485_SGND	Signal ground / cable shield connection

This RS485 port must be addressed as **port 2** when using the VPL API, such as the serOpen function.

RS485 port 2

The RS485 port is available on the angled front terminals.

If the TER2 jumper is inserted, a 120Ω endpoint resistor is enabled. For the location of TER2 refer to Appendix A

RS485 port 2 terminals

Terminal Name	Description
485_2_A	RS485 non-inverting signal (A)
485_2_B	RS485 inverting signal (B)
485_SGND	Signal ground / cable shield connection

This RS485 port must be addressed as **port 3** when using the VPL API, such as the serOpen function.

1-Wire

The 1-Wire bus is available on the angled front row terminals. All 1-Wire communication goes through a single connection, and all 1-Wire devices connected to this connection retrieve their power directly from the bus (called parasitic power). For this, only two wires are needed – the 1-wire signal and the ground reference, thus allowing minimal cable installations.

A dedicated output is available for 1-Wire ID-Button readers, which include a built-in LED. Please consult the RTCU IDE documentation for further information.

For further information regarding the modular 1-wire concept, please refer to the document "Modular 1-Wire Concept Technical Manual" on the Logic IO webpage.

1-Wire terminals

Name	Description
1Wire	1-Wire bus.
1Wire-LED	1-Wire ID-Button LED output.
SGND	Signal ground.

Specification of the 1-Wire bus:

	Max.	Unit
Total weight ¹	65	m

DC-Out 12/24VDC

A single 12V/24V DC output is available on the RTCU LX9 eco for supplying external equipment. It is possible to control the DC output to save power.

The DC output is short circuit- (to ground), ESD- and transient-protected.

Make sure not to exceed the current specification of the output and be aware of inrush currents of the external equipment that may exceed the specifications.

The DC output must be enabled from the application. Please consult the RTCU IDE on-line manual for more information.

¹³ The term of weight has been described in "Modular 1-wire concept – Technical Manual" document.

When using the jumper JP101, either 12V or 24V DC is available on the DC-out terminal. The 12V DC output can supply a maximum of 500 mA, and the 24V DC output can supply a maximum of 250 mA. The DC-Out is available on the top row of the stacked terminals. This output is named boardDCOut2 in the RTCU on-line help.

The 12V DC-out requires a DC supply voltage of a minimum of 14 VDC or AC supply, and the 24V DC-out voltage requires that the AC supply be present.

The jumper that switches the DC-out voltage level between 12V DC and 24V DC is located at the front of the communication terminal rows, as shown below:

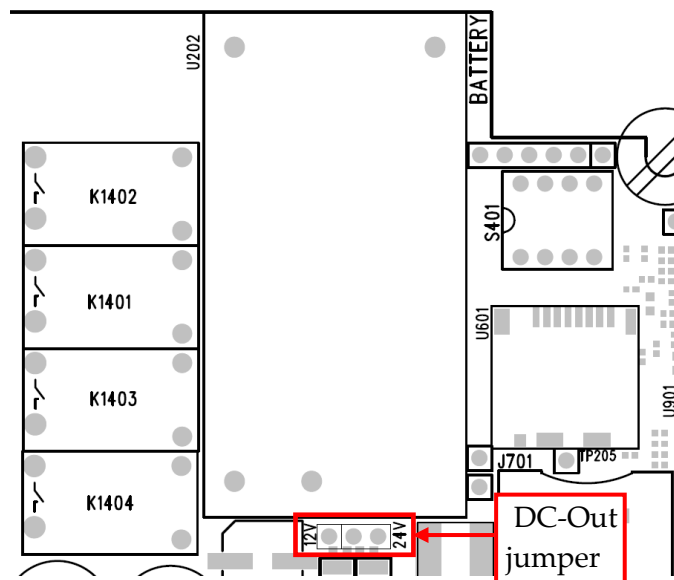

DC-Out terminals

Terminal Name	Description
DCOUT	+12V/ 500 mA / +24V/250 mA DC output for external equipment.
SGND	Signal ground.

LED Indicators

Four bi-colored (red and green) LED indicator is present on the front of the device (see graphical overview).

Two bi-colored LEDs (A and B) are available to the user, and the remaining two LEDs (S1 and S2) are signaling the status and possible errors of the RTCU device.

User LED A and B

LED A and B are composed of four individually controllable LEDs:

- LED named A on the front consists of LED 1 (green) and LED 2 (red).
- LED named B on the front consists of LED 3 (green) and LED 4 (red).

They are easily accessed from within the application program, and it is possible to mix the LEDs to obtain a third color: yellow. Please consult the RTCU IDE documentation for more information.

Fault mode

When a runtime error occurs, the device enters fault mode. This mode is indicated by a fast-blinking RED of both User LEDs A and B. Please use the RTCU IDE to obtain the fault log.

System LED S1 and S2

The RTCU is equipped with two system LEDs, which shows the status and possible errors of the RTCU device.

The different patterns are listed in the table below. If the color of the system LED S1 is yellow, the device is actively communicating with the RTCU IDE (or another program, supporting the RTCU RACP protocol).

The LED S2 signals either the cellular module activity or, if all other LEDs are off, that the RTCU is in the "wait for event" low power state.

S1: System LED1 pattern overview

Pattern	Description
Fastest blinking, green	The device is initializing, preparing to start the application.
Fast blinking, green S2 On, green	The device is installing an update. Depending on the kind of update, it may take some time
Fast blinking, green ¹	The device has been forced into recovery mode with the use of the system switch. The application is not executing.
500ms On / 500ms Off green ¹	The device is executing the application program
1.5s On / 0.5s Off. Green ¹	The device executes the application program while charging the internal backup battery.
Alternating Fast/Slow, green/orange	The device has lost its firmware! This can only happen if, during a firmware upgrade, the RTCU device loses power or the communication is lost completely. In this case, upload the firmware to the device again.
On yellow (and all other LEDs OFF)	The device is booting, initializing the system

¹ Or yellow when communicating with the RTCU IDE or another program, supporting the RTCU RACP protocol).

S2: System LED2 pattern overview (Cellular activity and "Wait For Event")

Pattern	Operating Status
Off	The cellular engine is turned off
600 ms On / 600 ms Off green	Missing SIM card or PIN code. Network search and logon in progress.
75 ms On / 3 s Off green	Logged on to the network.
75 ms On / 75 ms Off / 75 ms On / 3 s OFF green	A Packet/GPRS session is active.
Flashing green	Indicates Packet/ data transfer.
On green (and all other LEDs OFF)	The system is booting into recovery mode
10 s OFF / 50 ms ON green (and all other LEDs OFF)	The RTCU device is in a low-power "Wait For Event" state.

Switches

DIP-Switch

The RTCX LX9 eco device contains four dip-switches, and three of them are available for application use. The dip-switches are located inside the device (see the graphical overview).

System Switch (RST)

The RTCX LX9 eco device contains a combined reset/diagnostic switch. This switch is accessible from the inside of the device.

The RTCX device will perform a full reset by activating the switch shortly.

If the reset switch is held down for approx. 3 seconds¹, the device will instead enter recovery mode², and the application will not be started. The system will automatically turn on the cellular engine in recovery mode to connect to the network and RTCX Communication Hub (if configured).

Pressing reset will also activate the device when in power-down mode. If external power is removed and the backup battery is disabled, the reset switch can still be used to boot into recovery mode as long as enough power is left on the battery.

¹ System LED S2 will flash green three times when this state is entered.

² System LED S1 will indicate this state by fast blinking green or yellow.

Internal Li-Ion Backup Battery

The RTCU contains an internal Li-Ion battery for operation even when the external power is absent, making it possible to report power loss etc. Please note, that when external power is removed, the device will be powered down by default. This setting can be changed as documented in the RTCU IDE documentation.

The battery charging is entirely automated and handled internally by the RTCU device – leaving no need for user interaction. Different functions (Battery low, Charger enable, charging status, etc.) are available to the user application.

The charge current is relatively high for a shorter charge time, as specified in the technical specification. Make sure both the power supply and cables can handle the high current.

Whenever a power failure occurs, the battery will be charged to establish the capacity, thus making the battery ready for the subsequent power failure.

By default, the battery cannot be charged above 45°C or below 0°C. The RTCU offers to charge down to -10 °C using a specialized algorithm to protect the battery.

If the temperature is above 45°C, the charging will not start and will be postponed until it is below this threshold.

The temperature has a strong influence on the battery capacity. At 0°C, the capacity drops to approximately 60% of the initial capacity, and it falls dramatically at lower temperatures.

The battery cycle (numbers of charges and discharges) also influences the capacity. After 300 cycles, the capacity has dropped to approximately 80% of the initial capacity.

Warning

Misusing the RTCU device may damage the built-in battery security circuit.

- *Do not place the RTCU device in high-temperature locations such as in direct sunlight or near engines. Using the RTCU device in this environment may result in a loss of battery performance and a shortened life expectancy.*
- *Do not expose the device to water, salt water, or allow the battery to get wet.*
- *Avoid strong impacts and shocks.*

Wireless Communication

LTE Cat. 1 Cellular Engine

The RTCU LX9 eco uses an LTE/UMTS/HSPA engine with the following features:

- Max. 10Mbps down / 5Mbps upload (Cat 1)
- LTE-FDD: B1/ B3/ B7/ B8/ B20/ B28A.
- WCDMA: B1/ B8
- GSM: 900/1800 MHz
- SMS (Text and PDU)
- UMTS release 7.
- Digitized audio / DTMF capability.

The Cellular Engine is designed for operating in the EMEA (Europe, Middle-East, Asia) regions.

Bluetooth LE

The RTCU LX9 eco has an onboard Bluetooth LE 5.3 certified radio operating at the standard 2.4 GHz spectrum.

Internal SIM-Card reader

The RTCU LX9 eco device contains a standard mini-SIM card reader which is located inside the device (see drawing below or graphical overview) and is easily accessed. The SIM card reader is lid-based with a mechanical lock system for secure SIM card installation. Please refer to Appendix B for the SIM card installation guide. The RTCU LX9 eco is prepared for an internal eSIM, which shares the SIM card signals with the SIM reader. Please contact Logic IO for this option.

If the SIM card is removed during cellular operation, the device will be rejected from the network shortly after.

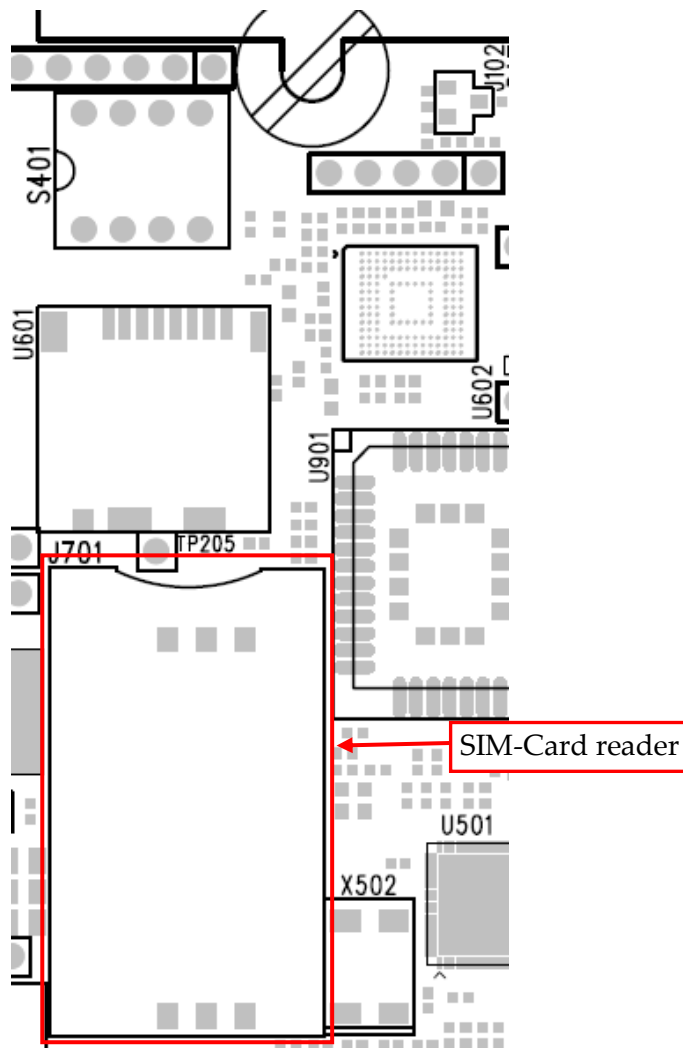

Micro SD-Card reader

The RTCU LX9 eco device has a standard Micro SD card reader located inside the device (see drawing below or graphical view). The Micro SD card reader is a lid-based system with a mechanical lock for reliable insertion and operation.

The RTCU LX9 eco supports a FAT filesystem with up to 32 GB capacity support for standard PC compatibility. Please refer to Appendix C for the SD-Card installation guide.

Please consult the RTCU IDE on-line help for more information on using the SD-Card. Avoid removing the Micro SD card during access to the card.

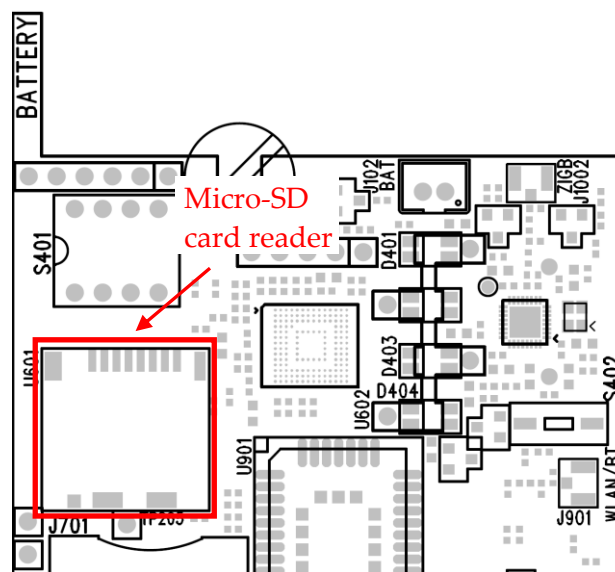

Approved Micro SD cards

To ensure the highest performance and compatibility it is important to use SD-CARDS that have been approved and tested by Logic IO.

Commercial-grade SD-CARDS can be used in applications where the limited write endurance is acceptable - for example, if the SD-CARD is often replaced. Commercial-grade SD-CARDS should *not* be used in applications where a potential failure on the media is considered mission-critical.

For applications that use the SD-CARD media extensively and where a failure is critical, it is recommended to use approved **Industrial Grade** SD-CARDS.

Logic IO has approved and recommends industrial-grade SD-CARDS from **ATP** that is available in capacities from 512 MB to 32 GB.

ATP Industrial Grade SD/SDHC Cards are optimized for demanding industrial applications and consistently perform in all conditions. ATP uses reliable SLC flash technology with a flash endurance of more than 20 times higher than commercial-grade MLC flash products.

The differences in write endurance between commercial grade MLC flash and ATP Industrial grade SLC flash are quite remarkable for write-intensive applications:

Product Line	Details	Total Writeable Data Prediction @ 1GB	Time Prediction @ 500 writes a day (1GB)
ATP Industrial Grade	SLC Flash	80,000GB	5,740 days
	+ Advanced Wear Leveling	or 2,800,000 writes	or 15.7 years
Commercial Grade	Grade A MLC (2 bits per cell)	4,000GB	280 days
	+ Advanced Wear Leveling	or 140,000 writes	

Antennas

Cellular Antenna

The RTCU LX9 eco device contains an SMA female connector for connecting a suitable LTE-compliant antenna. When installing the antenna, please ensure that the antenna is not close to metallic parts or anything else that can influence the antenna's efficiency.

Please consult the installation guide that follows the antenna.

Bluetooth Antenna

The RTCU LX9 eco device contains an internal antenna for the Bluetooth LE.

Product Identification Label with Barcode

The RTCU LX9 eco product identification on the device's exterior contains a unique serial number in readable form and a barcode.

The first three digits in the serial number identify the device type, and for the RTCU LX9 eco device, this unique code is **392**.

Barcode format used: 2/5 Interleaved with check-digit.

Power Consumption

The table below shows detailed information about the RTCU LX9 eco device's typical power consumption while operating.

DC power consumption: Device operating in normal mode

	12V	24V	BAT		
Device active	55	30	140	mA	
Device active with Cellular on*	60	30	150	mA	idle @ -63dBm* (2G)
Device active with GPRS session*	145	75	400	mA	@ -65dBm, Battery not charging*
Device active while charging	450	250	-	mA	

Note: Values marked with (*) are averaged and should be considered guidelines as they may vary depending on the cellular signal strength.

Note: Power consumption from a fully charged battery

AC power consumption: Device operating in normal mode

	220V AC			
Device active	1	W		
Device active with Cellular on*	1.5	W		idle @ -63dBm* (2G)
Device active with GPRS session*	3	W		@ -65dBm, Battery not charging*
Device active while charging	6.5	W		

Note: Values marked with (*) are average and should be considered guidelines as they may vary depending on the cellular signal strength.

The table below shows detailed information about the RTCU LX9 eco device's typical power consumption in power-saving modes.

The following power-saving modes are supported:

- Mode 1: LED blinks every ~10 s, and resumes the application when it is awoken.
- Mode 3: Does not blink, resets the device when it is awoken.

See the RTCU IDE on-line manual for information about how to use the power-saving modes.

DC power consumption: Device operating in power-saving modes

Wakeup source	Mode 1			Mode 3			
	12V	24V	BAT	12V	24V	BAT	
Cellular*	2	1.5	5.5	-	-	-	mA
RS232 Mode 1	0.9	0.5	2.6	-	-	-	mA
RS485 Mode 1	0.8	0.5	2.6	-	-	-	mA
Din 1-5, normal mode	0.8	0.5	2.6	0.2	0.15	0.7	mA
Din 1-4, S0 mode	16.1	14.7	-	-	-	-	mA
Power Failure	0.8	0.5	2.6	-	-	-	mA
Power Apply	0.8	0.5	2.6	0.2	0.15	0.7	mA
Time	0.8	0.5	2.6	0.2	0.15	0.7	mA

Note: Power consumption from the battery @ 3.8V

Note: Values marked with (*) are averaged and should be considered guidelines, as they vary depending on the signal strength.

AC power consumption: Device operating in power-saving modes

The power consumption from external AC is less than 1 W in all the power-saving modes.

Appendices

Appendix A – Device configuration guide

The RTCU LX9 eco has many features; some require configuration by using hardware jumpers inside the device. A brief overview over the jumper settings can be found in the following table.

Feature	Jumper	State	Default state
Communication	TER1 (<i>RS485_1</i>)	Installed Not installed	120Ω resistor enabled. 120Ω resistor disabled (<i>default</i>).
	TER2 (<i>RS485_2</i>)	Installed Not installed	120Ω resistor enabled. 120Ω resistor disabled (<i>default</i>).
Analog input	JPAI1	Installed Not installed	AI1 current measurement. AI1 voltage measurement (<i>default</i>).
	JPAI2	Installed Not installed	AI2 current measurement. AI2 voltage measurement (<i>default</i>).
Digital input	JPDI1	Position S Position N	DI1 S0 (<i>default</i>). DI1 normal.
	JPDI2	Position S Position N	DI2 S0 (<i>default</i>). DI2 normal.
	JPDI3	Position S Position N	DI3 S0 (<i>default</i>). DI3 normal.
	JPDI4	Position S Position N	DI4 S0 (<i>default</i>). DI4 normal.
DC-Out voltage	JP101	Position 12V Position 24V	12V DC out (<i>default</i>). 24V DC out.

TER1 and TER2

Enables/disables onboard 120Ω line termination resistors which are according to standards; RS485 communication requires a proper line termination value (120Ω *assuming a CAT5 twisted pair cable is used*) resistors in both ends of the bus. If the RTCU LX9 eco device is used as endpoint, the relevant jumper can be installed.

JPAI1 and JPAI2

These jumpers are used to select between current and voltage input. With a jumper installed on the relevant analog input, it will measure current between 0-20mA.

JPDI1, JPDI2, JPDI3 and JPDI4

These select either normal or Class A S0 input for DIN1-4. With the relevant jumper installed in position "S", the input is configured to S0, and when installed in position "N", the input is a normal digital input.

12V and 24V

These jumpers are used for connecting the DC OUT terminal to 12V or 24V.

Appendix B – Installing the SIM card

The SIM card reader is a lid-based type with a mechanical lock for secure SIM card installation.

Open the hinged lid of the SIM card reader, orientate the card as shown below, and insert it into the lid of the card reader. Close the lid and slide the metal locking mechanism to the locked position, as shown with an arrow and text on the lid, until a click is heard.

To remove the card, slide the metal locking mechanism to the unlocked position as shown with an arrow and text on the lid, and open the lid. The SIM card can now be removed.



SIM card orientation.

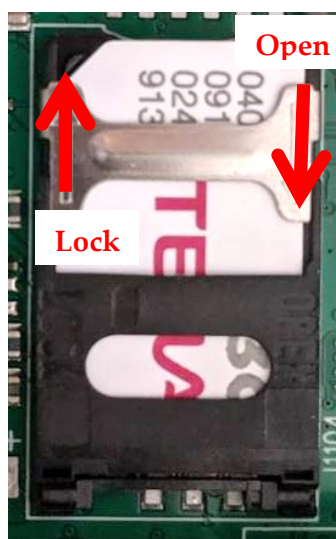

SIM inserted and locked

Appendix C – Installing the Micro SD card

To insert a Micro SD card into the reader, open the hinged lid of the card reader, orientate it as shown below, and push the card into the lid. Close the lid and slide the metal lid in the direction shown with an arrow on the lid until a click is heard.

Remove the card by sliding the lid in the direction shown with an arrow on the lid and then open the lid. Avoid removing the Micro SD card when accessing the card.



Micro SD card orientation

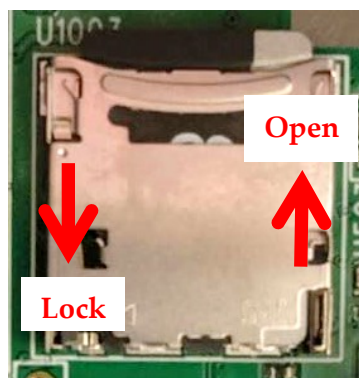

Micro SD card inserted and locked.

Appendix D - Open-Source Disclaimer

The RTCU LX9 eco products include several open-source software tools. This open-source software is governed by the terms and conditions of the applicable open-source license. You are bound by the terms and conditions of the appropriate open-source license in connection with your use and distribution of the open-source software in this product.

Please refer to the separate document "**RTCU Open Source Licenses.pdf**" for detailed information about the packages used.

RTCU LX9 eco Specifications

RTCU M2M Platform

- NX32 for Linux - NX32L.
- Fully NX32 compatible.
- Larger capacity and higher performance compared to NX32.
- Open and user-extendable API.
- RTCU M2M Platform SDK.

LX Hardware Core

- Powerful 32-bit ARM processor.
- Hardware floating point and DSP.
- 128 Mbyte RAM.
- Up-to 512 Mbyte NAND flash.
- Real-time clock with battery-backup.

Security

- Embedded firewall.
- TLS/SSL support with full certificate management.
- TLS/SSL support for SMTP, MQTT, FTP, HTTP, RTCU Communication Hub and TCP/IP sockets.
- Hardware assisted strong encryption/authentication: AES-128, AES-192, AES-256, DES, TripleDES, HASH, RND and RSA signature.

Storage

- Persistent data flash.
- Non-volatile SRAM.
- Internal flash drive (Up-to 64 MByte).
- Circular datalogger.
- Micro SD-card.

Bluetooth

- Bluetooth Low Energy 5.3.
- IEEE 802.15.4-2011 PHY
- Optional: Zigbee and OpenThread.

Cellular Engine

- LTE Cat.1 Engine (EMEA).
Max 10 Mbps(DL)/Max 5 Mbps(UL).
LTE FDD: B1/B3/B5/B7/B8/B20
LTE-TDD: none.
WCDMA: B1/B5/B8
GSM: B3/B8.
- DTMF decoding / transmission.
- Digitized voice playback / IVR.
- Internal SIM card-reader, with Mini-SIM 1.8/3 volt.
- Optional eSIM.

Audio

- Fully digitized audio system.
- Transfer, store and play audio.
- Digitized cellular audio.

Wired Communication

- 2 x RS232. One with control signals.
- 2 x RS485.
- 1-Wire bus.
- USB service/programming port.

User Interaction

- 4 x bi-colour LED.
- DIP-switches.
- I/O configuration jumpers for analog and digital operating modes.
- Jumpers for RS485 termination
- Reset / recovery switch.

Sensors

- Temperature sensor.

Digital I/O Interface

- 4 x relay output.
Max. 5A @ 250VAC / 30 VDC
- 5 x digital inputs.
Logic high: 8 to 40 VDC.
Logic low: -5 to 3 VDC.
Impedance: 13.8kohm @ 12V.
- 4 x IEC62053-31 Class A input.
- I/O expansion Modbus modules.

Analog I/O Interface

- 2 x analog inputs.
Range is 0..10VDC or 0..20 mA
Resolution: 12 bit
Accuracy: Typ. $\pm 0.2\%$ FSR @ 25°C
Impedance: 40 kohm (V)/500 ohm (C).
- Protected against transients and low-pass filtered.
- I/O expansion Modbus modules.

Electrical

- Supply operating range:
8 to 36 VDC.
100 to 260 VAC.
- Short and reverse power protected.
- 12/24V DC-out @ 500/250 mA.

Battery and Charger

- On-board 1 Ah (nominal) Li-Ion battery.
- Intelligent charger with temperature throttle and sub-zero degrees support.
- On-board temperature sensor.

Power Management

- Low-power modes.
- Wait for Event: Timer, Digital input, RS232/RS485, Cellular, Power change.
- Power consumption:
down to 0.2 mA@12V.
- Supervision of supply voltage / type.

Internal Interfaces

- Plug-compatible with the NX-910.
- Micro SD-Card slot with presence detection.
- Mini SIM-card slot.
- Service-port (Mini USB-B).
- Screw-terminals for:
Power, I/O and DCOUT.
- Angled screw-terminals for:
RS232, RS485, 1-Wire and DC-out.
- Jumpers for RS485, I/O and DC-out operating modes.
- Internal BLE Antenna.

External Interfaces

- 3 x M20 cable glands.
- SMA female connector for cellular.

Physical Characteristics

- Encapsulation:
Durable Polycarbonate plastic.
- TPE gasket.
- Colour: RAL 7035—light grey.
- Approx. 700 gram without accessories.
- W 130 x H 180 x D 60 mm.
(without external connectors)

Environmental Specification

- Operating temperature: -40 to 60°C.
- Battery charge temperature:
-10 to 45 °C
- Recommended storage temperature:
0 to 45°C.
- Humidity: 5..90% (non condensing).
- Impact resistance: IK08 [EN62262]
- UV resistance: UL 508.
- Flammability Rating: UL746C 5"
- Ingress Protection: IP65 [EN60529].

Approvals

- 2014/53/EU Radio Equipment Directive.
- 2014/30/EU EMC Directive
- 2011/65/EU RoHS Directive.
- Cellular:
GCF/CE/FCC/PTCRB/IC/Anatel/SRRC/NAL/
CCC/KC/NCC/JATE/TELEC/RCM/IFETEL/
FAC/NBCT/ICASA.

Warranty

- Two-years return to factory parts and labor.
- Optional warranty up to 5 years.
(restrictions apply).



**** END OF DOCUMENT ****